

# A Shop Tip From Don Butler

When making multiple biscuit slots in the vertical (one slot above the other, to get more holding power on a thick workpiece), only set the fence of the jointer tool once.

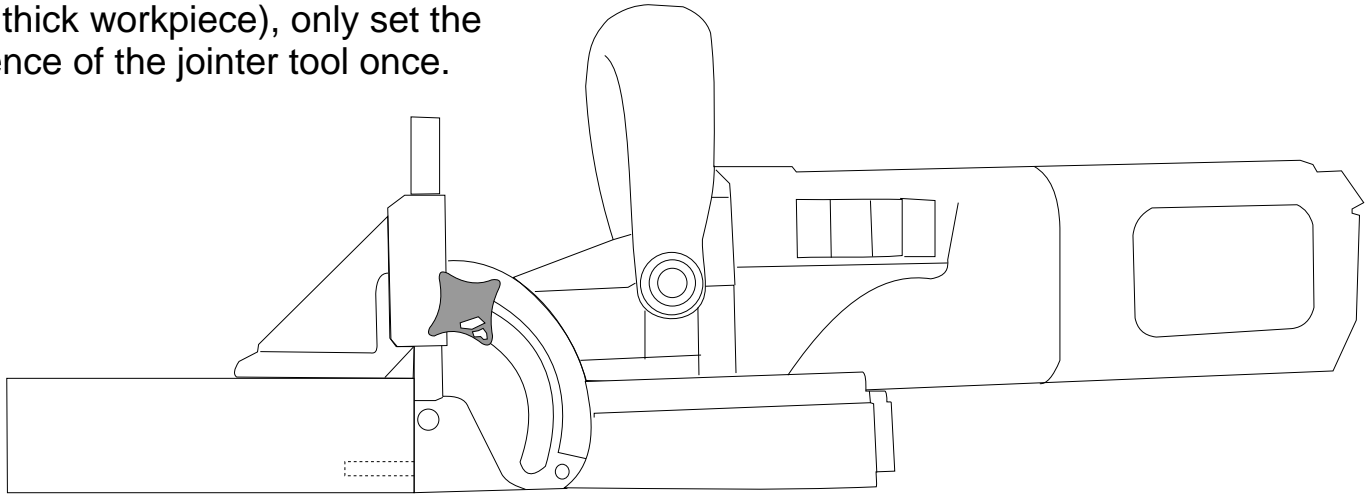

For the lower slots, set the fence for the board thickness as usual and cut all the slots at that level.

But when you're ready to make the slots above that level, do this:

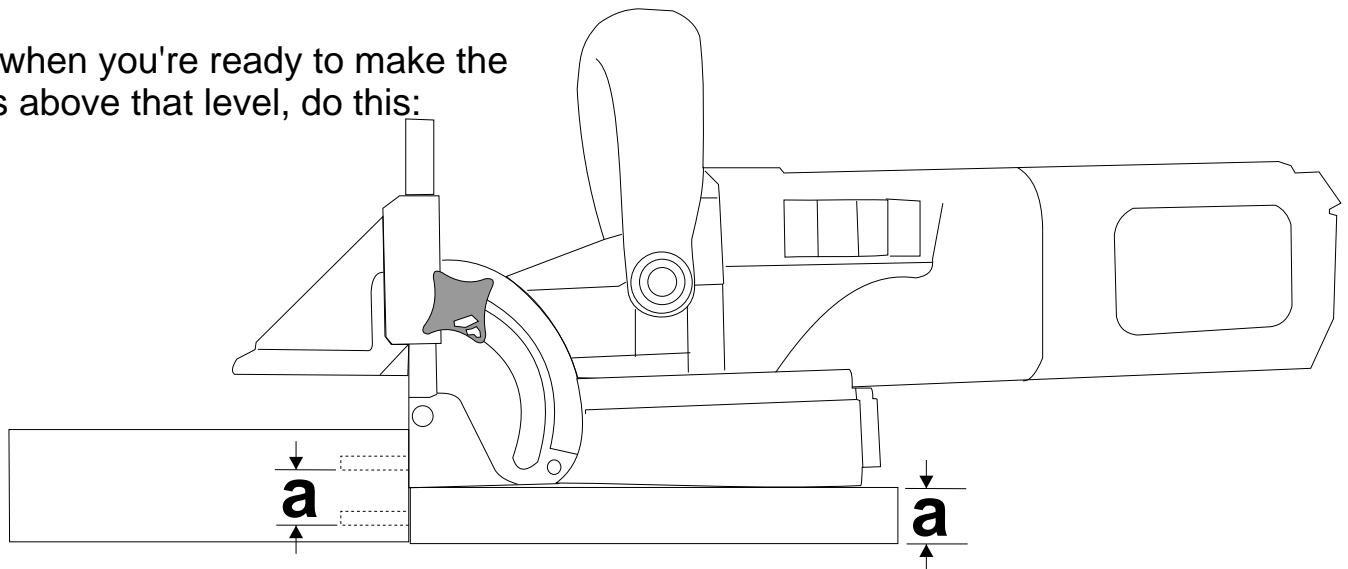

Decide on the amount you want to raise the jointer and just slip a board of that thickness (a) under the biscuit cutter. The slots will be just where you want them and you only set the fence once.

A handwritten signature in black ink that reads "Don".