

Some ideas for plywood panel construction

There is some very nice looking ply-wood out there, but getting it to look good in the assembly isn't always easy, and edge banding isn't always the answer. But utilizing solid wood corners into which the plywood edges can be fastened can make it very nice, indeed.

Here's a few ideas to get you started.

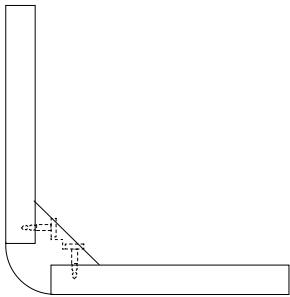

Rounded Corner Construction. A nice touch and modern looking. Use a rounded corner piece with a flat on the inside and two notches for the plywood sides. Notice the pocket screws that secure the plywood from the inside.

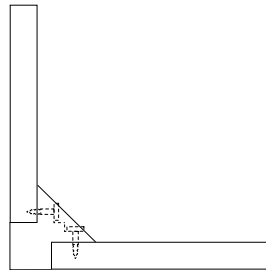

Square Corner Design. The easiest to make. Use straight cut corner pieces with notches for the panels. Pocket screws hold the plywood.

The pocket hole idea is common to all the styles.

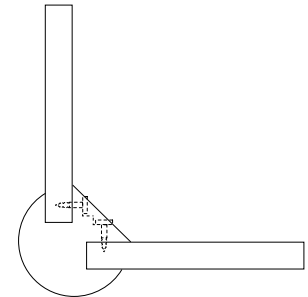
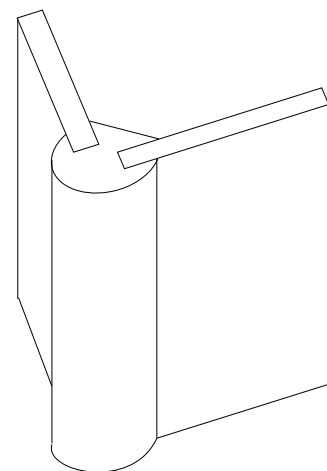
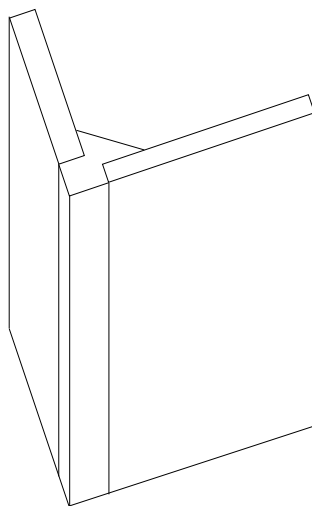
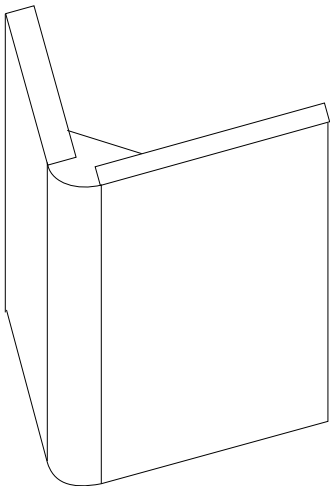

Table Leg Corner Construction. By using a larger round and placing the notches back toward the inside, the corner appears to have been joined to a sort of table leg. This style is currently quite popular in kitchen counter and cabinet design. The corner can be fluted or even have turned features with the feet right on the bottom end.



These techniques are used all the time in commercial woodworking for cabinets and counters in some very upscale buildings. Using plywood provides stability not to be found in solid wood and furniture grade plywood is usually free from voids and comes in some very nice face veneers.